

BOLAB
SYSTEMS GMBH

Arbitrary 4-Quadrant Amplifier

110-70N-T

BOLAB Systems GmbH

100-TS Series

Arbitrary 4-Quadrant Voltage and Current Amplifiers

400 W - 18.000 W
DC ... 200 kHz / 1 MHz



Contact

Phone : +49 74 28 / 94 52 42 - 0
Email : info@bolab-systems.de
Web : www.bolab-systems.com

BOLAB

BOLAB Systems GmbH
Muehlstetten 3
72351 Geislingen, Germany



Arbitrary 4-Quadrant Voltage and Current Amplifiers

100-TS Series

Standards: LV124, LV148, VW 80000, BMW GS 95024-2, BMW GS 97092, ISO 7637-2, ISO 16750-2, MBN LV124, MBN LV148, VDA 320, JLR, PSA, GMW, etc.

110-70N-TS

● DAQ status

● Protection

● Ready

Supply Voltage

High

Mid

Current Mode

Output On/Off



POWER



Arbitrary 4-Quadrant Voltage and Current Amplifiers

400 W - 18.000 W
DC - 200 kHz / 1 MHz

Special Features

- DC ... 200 kHz full range bandwidth
- DC up to 1 MHz (small signal -3 dB)
- Output voltage 35 V / 70 V / 75 V
- Rise time / fall time up to 100 V/ μ s
- Arbitrary function with 1 Million memory data points
- Internal resistor 0 ... 200 m Ω (Option)
- Analogue input 0 ... \pm 10 V for voltage control
- Option for running as current amplifier
- Monitor outputs for measured values of voltage and current
- WaveMaster software for graphical waveform generation
- Simulation of imported oscilloscope signals
- Modularly expandable up to 18 kW (Systems > 1 kW)
- USB interface standard
- Voltage resolution less than 0.001 V
- Linearity 0,1% DC
- DC - Offset < 1 mV
- DLL's for C++, LabViewTM, Vector-CAPL, Python, C#, MathLab, etc.

Model 35R-TS Overview

-30 V / +35 V

Models	Low voltage -30 V...+16 V	Medium voltage -30 V...+27 V	High voltage -30 V...+35 V	Output Power	Size
105-35R-TS	15 A	15 A	11 A	400 W	3 U
110-35R-TS	38 A	38 A	28 A	1.000 W	4 U
120-35R-TS	76 A	76 A	55 A	2.000 W	14 U
130-35R-TS	114 A	114 A	83 A	3.000 W	18 U
140-35R-TS	152 A	152 A	110 A	4.000 W	22 U
150-35R-TS	190 A	190 A	138 A	5.000 W	26 U
160-35R-TS	228 A	228 A	165 A	6.000 W	30 U
180-35R-TS	304 A	304 A	220 A	8.000 W	2 x 22 U
200-35R-TS	380 A	380 A	276 A	10.000 W	2 x 26 U
220-35R-TS	456 A	456 A	331 A	12.000 W	2 x 30 U
250-35R-TS	570 A	570 A	413 A	15.000 W	3 x 26 U
280-35R-TS	684 A	684 A	496 A	18.000 W	3 x 30 U



Example: Model 110-35R-TS

Low Voltage Range

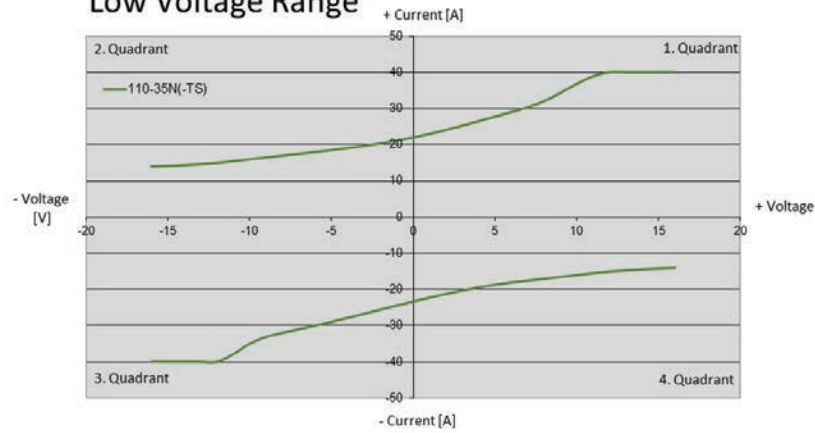

Middle Voltage Range

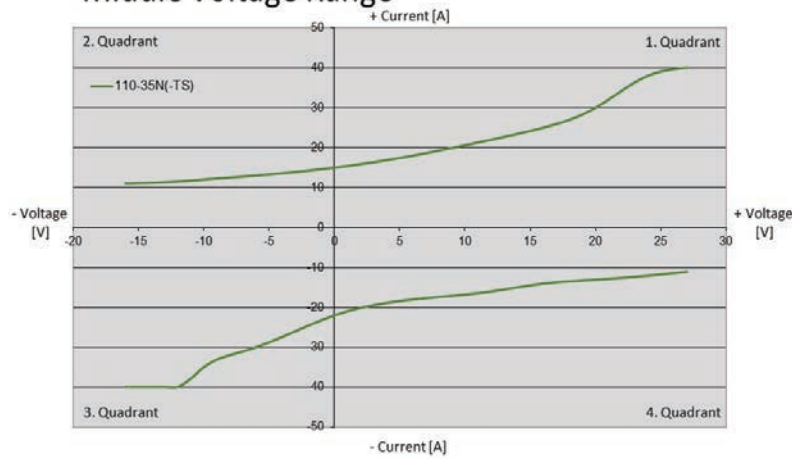

High Voltage Range

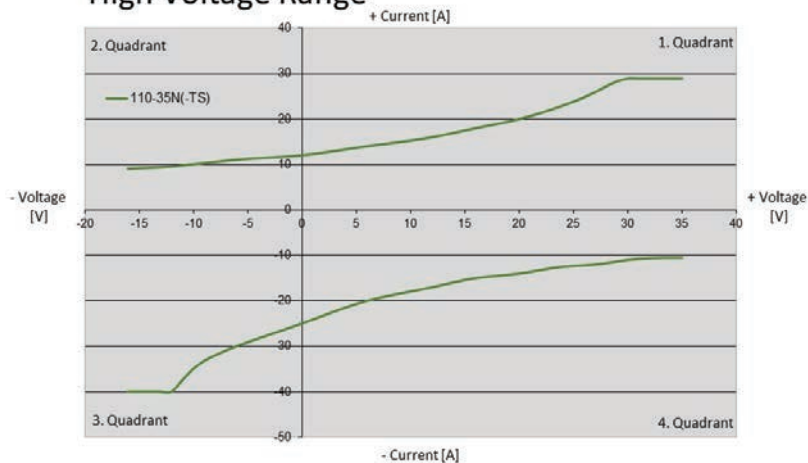

500 W - 18.000 W DC - 200 kHz / 1 MHz



Model 110-70R-TS Overview

-30 V / +70 V

Models	Low voltage -30 V...+16 V	Medium voltage -30 V...+27 V	High voltage -30 V...+35 V	Output Power	Size
105-70R-TS	19 A	15 A	11 A	400 W	3 U
110-70R-TS	38 A	38 A	28 A	1.000 W	4 U
120-70R-TS	76 A	76 A	55 A	2.000 W	14 U
130-70R-TS	114 A	114 A	83 A	3.000 W	18 U
140-70R-TS	152 A	152 A	110 A	4.000 W	22 U
150-70R-TS	190 A	190 A	138 A	5.000 W	26 U
160-70R-TS	228 A	228 A	165 A	6.000 W	30 U
180-70R-TS	304 A	304 A	220 A	8.000 W	2 x 22 U
200-70R-TS	380 A	380 A	276 A	10.000 W	2 x 26 U



Models	Low voltage -30 V...+16 V	Medium voltage -30 V...+27 V	High voltage -30 V...+35 V	Output Power	Size
220-70R-TS	456 A	456 A	331 A	12.000 W	2 x 30 U
250-70R-TS	570 A	570 A	413 A	15.000 W	3 x 26 U
280-70R-TS	684 A	684 A	496 A	18.000 W	3 x 30 U



3 kW Test System

Extremely Powerful

Modular Design

Unlimited Signal Waveforms

Example: Model 110-70R-TS

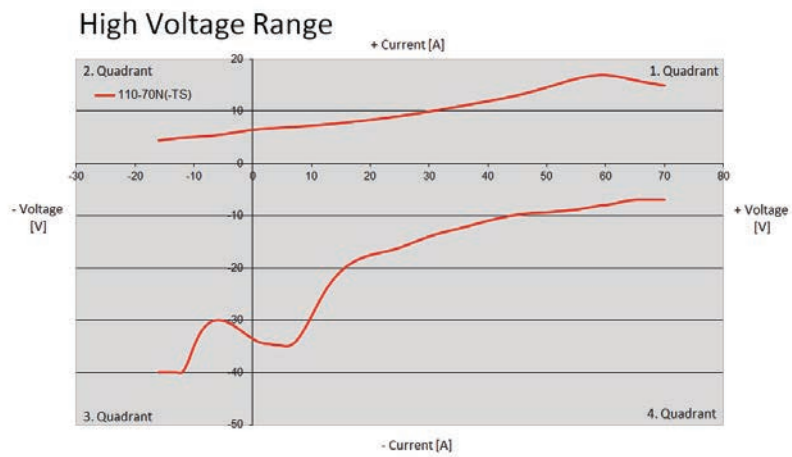
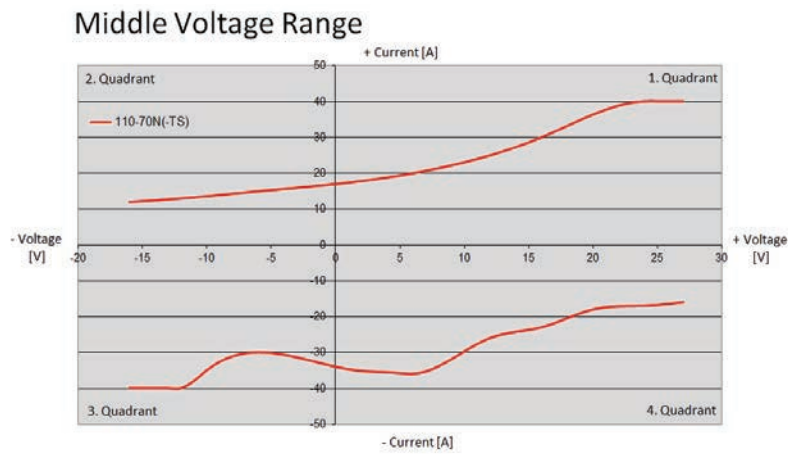
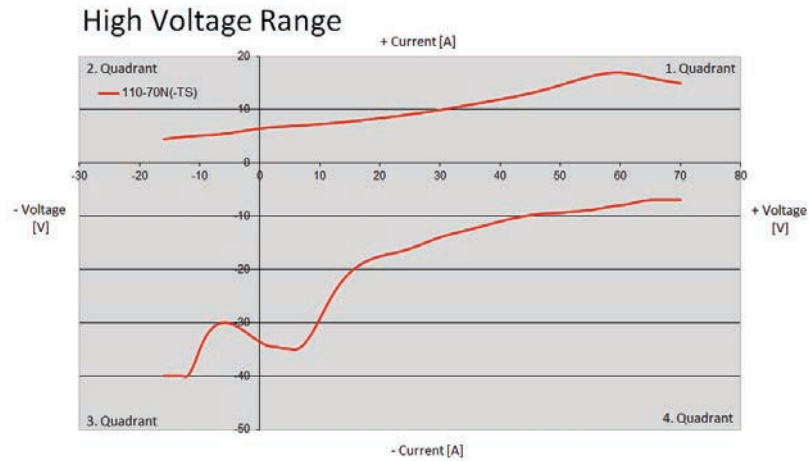

500 W - 18.000 W
DC - 200 kHz / 1 MHz



Model 105-75N-TS Rear

Selectable Operating Voltage

Three selectable operating-voltage ranges allow to adapt to applications for high voltage / low current or low voltage / high current.

Especially when controlling extremely low impedance loads, the operating voltage range can be reduced to one third of the maximum output voltage. This leads to an immense reduction of power dissipation.

- Reduction of power dissipation
- One system for 12 V / 24 V / 48 V vehicles

Model 75N-TS Overview

-75 V / +75 V

Models	Low voltage -25 V...+25 V	Medium voltage -50 V...+50 V	High voltage -75 V...+75 V	Output Power	Size
105-75N-TS	19 A	10 A	7 A	500 W	3 U
110-75N-TS	38 A	19 A	14 A	1.000 W	4 U
120-75N-TS	76 A	38 A	27 A	2.000 W	14 U
130-75N-TS	114 A	57 A	40 A	3.000 W	18 U
140-75N-TS	152 A	76 A	53 A	4.000 W	22 U
150-75N-TS	190 A	95 A	67 A	5.000 W	26 U
160-75N-TS	228 A	114 A	80 A	6.000 W	30 U
180-75N-TS	304 A	152 A	106 A	8.000 W	2 x 22 U
200-75N-TS	380 A	190 A	133 A	10.000 W	2 x 26 U
220-75N-TS	456 A	228 A	160 A	12.000 W	2 x 30 U
250-75N-TS	570 A	285 A	200 A	15.000 W	3 x 26 U
280-75N-TS	684 A	342 A	239 A	18.000 W	3 x 30 U

Example: Model 110-75N-TS

Low Voltage Range

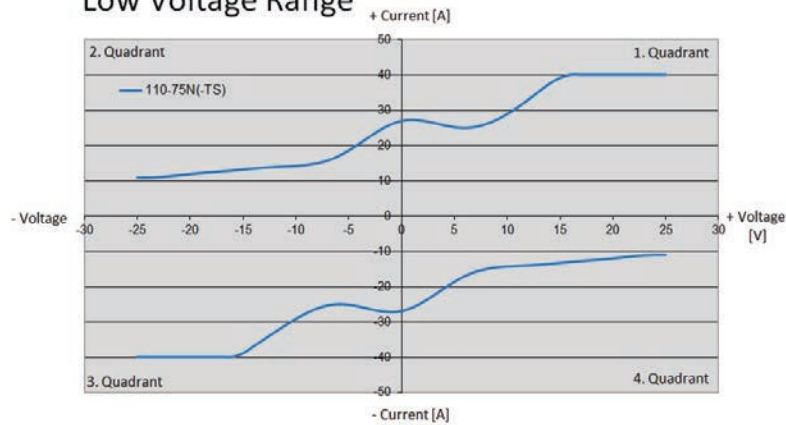

Middle Voltage Range

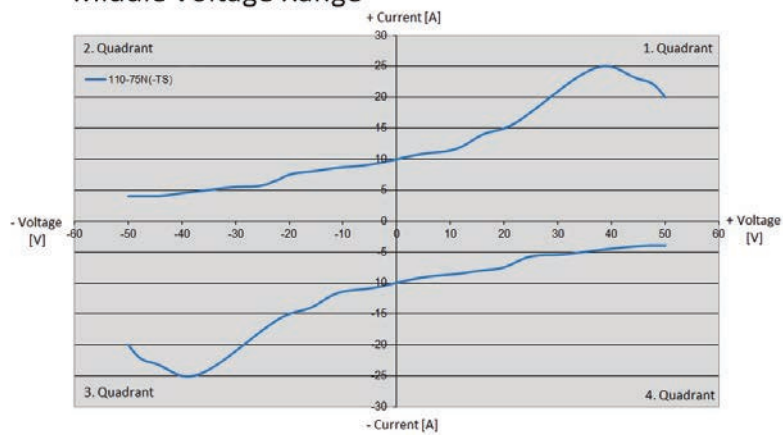

High Voltage Range

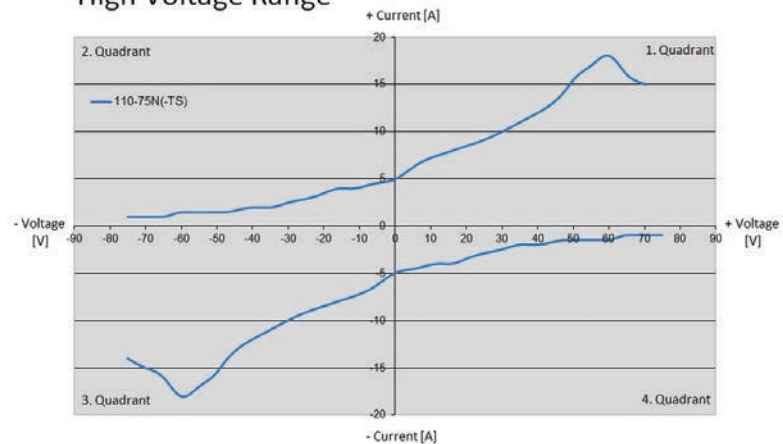



Comparison

110-70R (-30 V ... +70 V, 40 A, 1000 W with
110-75N- (-75 V ... +75 V, 40 A, 1000 W)

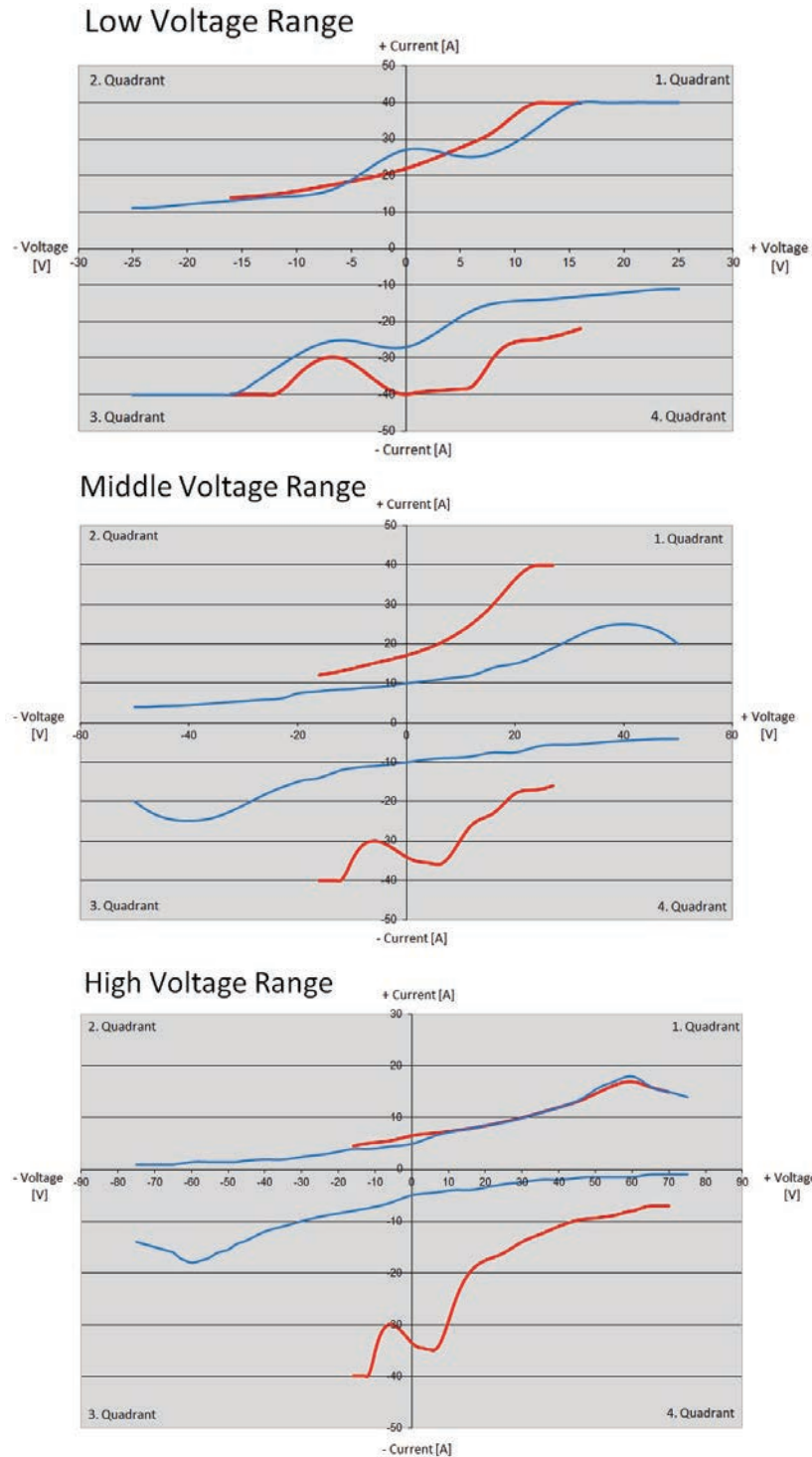

160-70R (-30 V ... +70 V, 228 A, 6000 W with 160-75N- (-75 V ... +75 V, 228 A, 6000 W)

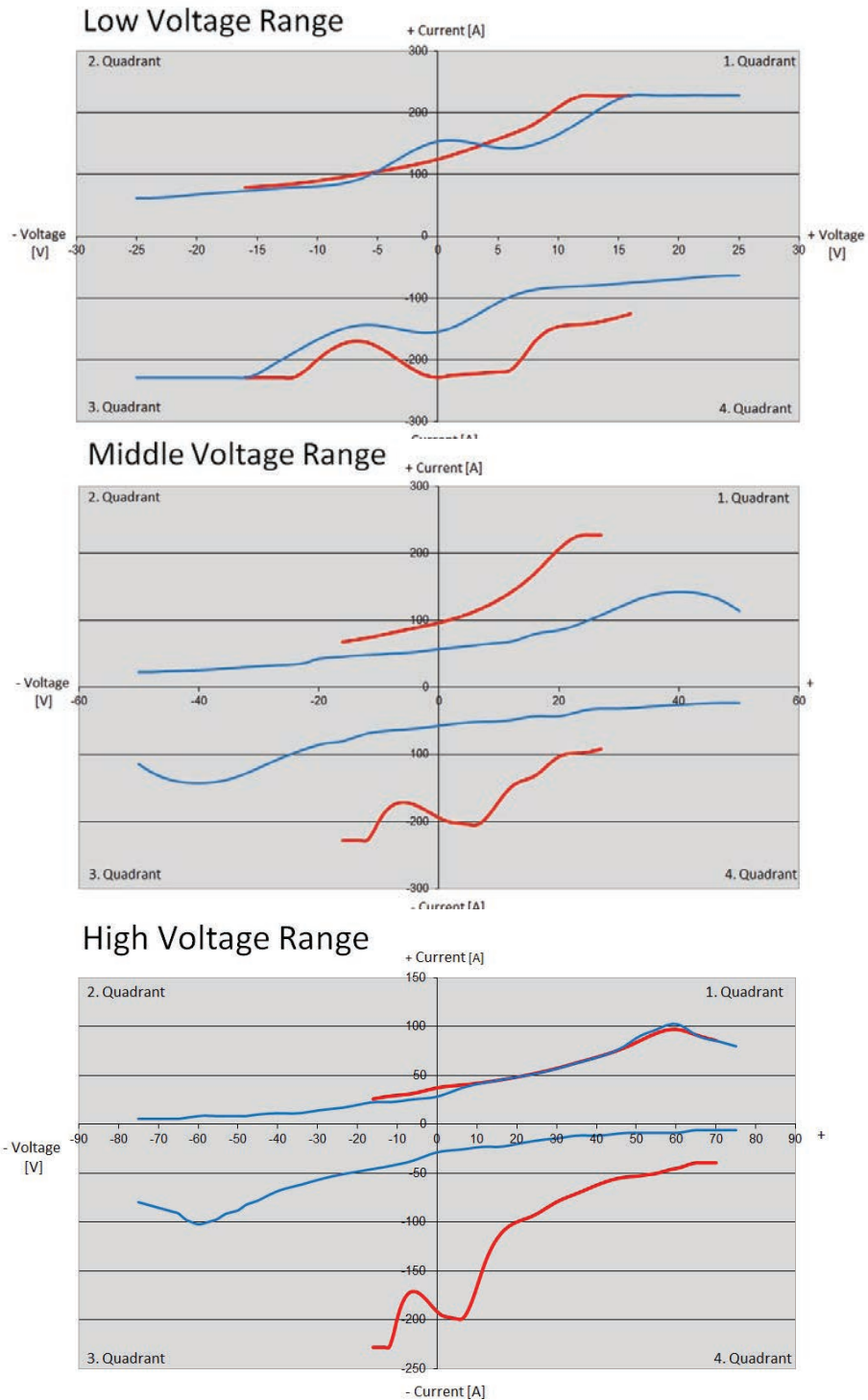

Test System Architecture

Multiple Instrument Functions In One Device

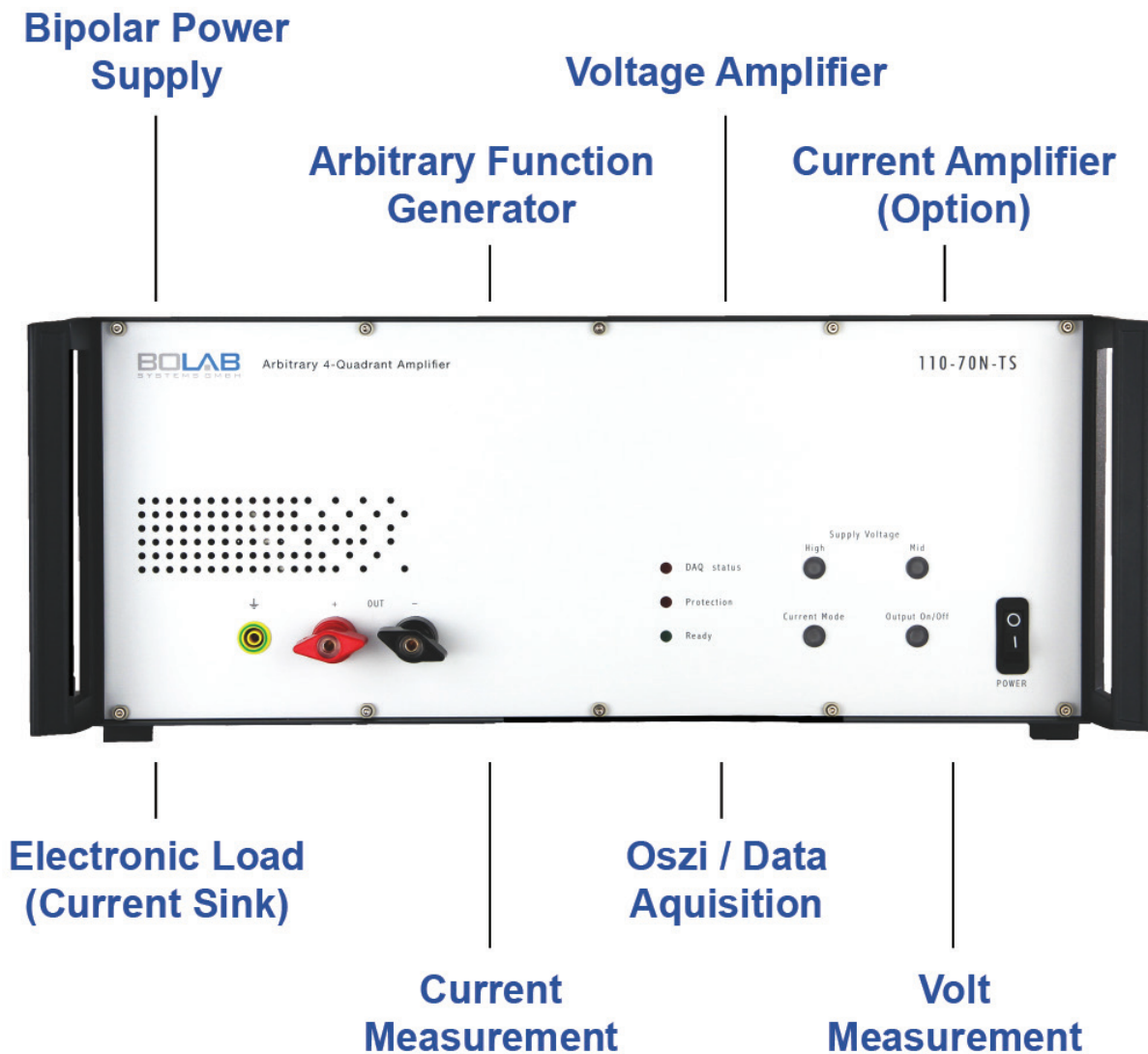

General

The 100-TS series are linear precision 4-quadrant power amplifiers for fast voltage and current signals - each positive and negative (bipolar).

They also work as sink in applications to absorb power. Extremely high bandwidth at highest power requirements, necessary for fast signals, characterizes this series. Especially these amplifiers are characterized by their signal quality.

Arbitrary Functionality

BOLAB's arbitrary power amplifiers include a huge memory of 1 Million data points to store arbitrary waveforms in the instrument itself. No arbitrary waveform generator or any other controlling instrument is needed which makes these 4-quadrant amplifiers unique in the world market.

The easy-to-use WaveMaster software, that is standard in scope of delivery, allows to generate waveforms with a graphical user interface or via tabular input.

Monitor Outputs

Located on the back of the instruments there are monitor outputs for voltage and current with the respective measured values.

Output values are $0 \dots \pm 10 \text{ V}$ for $0 \dots \pm V_{\text{rated}}$ respectively $0 \dots \pm I_{\text{rated}}$. The current is measured with an internal shunt and accuracy of approx. 1 %. Optionally a current sensor with 0.01 % accuracy can be integrated easily.

Output ON/OFF

With its output on/off switch at the front of the instruments, the output can be activated or deactivated. When deactivating, there is a complete galvanic separation to the devices under test.



● Protective Functions

Various protective functions avoid damage of the instrument and guarantee protection for the devices under test.

Output voltage and current can be limited. Over-temperature shutdown is included. The unit's internal calculation of power dissipation and complete monitoring of current ensure perfect short circuit and over-voltage protection.

Also, for security reasons an interlock shut down can be triggered.

● Short-Time Current

Within 500 ms, the amplifier systems supply a short-time current.

E.g. the 1.000 W, 40A will reach 100 A in 500 ms.

Generally the instruments provide a shorttime current of approximately two times higher than $I_{DC Max}$

● Short Time Current At Model 110-75N-TS

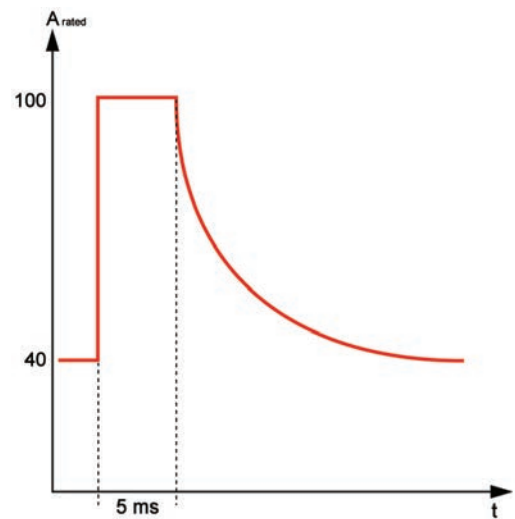

Signal Quality

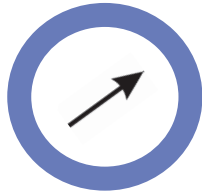

RISE TIME: $< 1 \mu\text{s}$

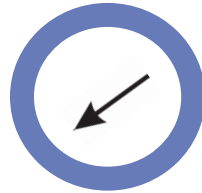

FALL TIME: $< 1 \mu\text{s}$



NO OVERSHOOT /
NO UNDERSHOOT

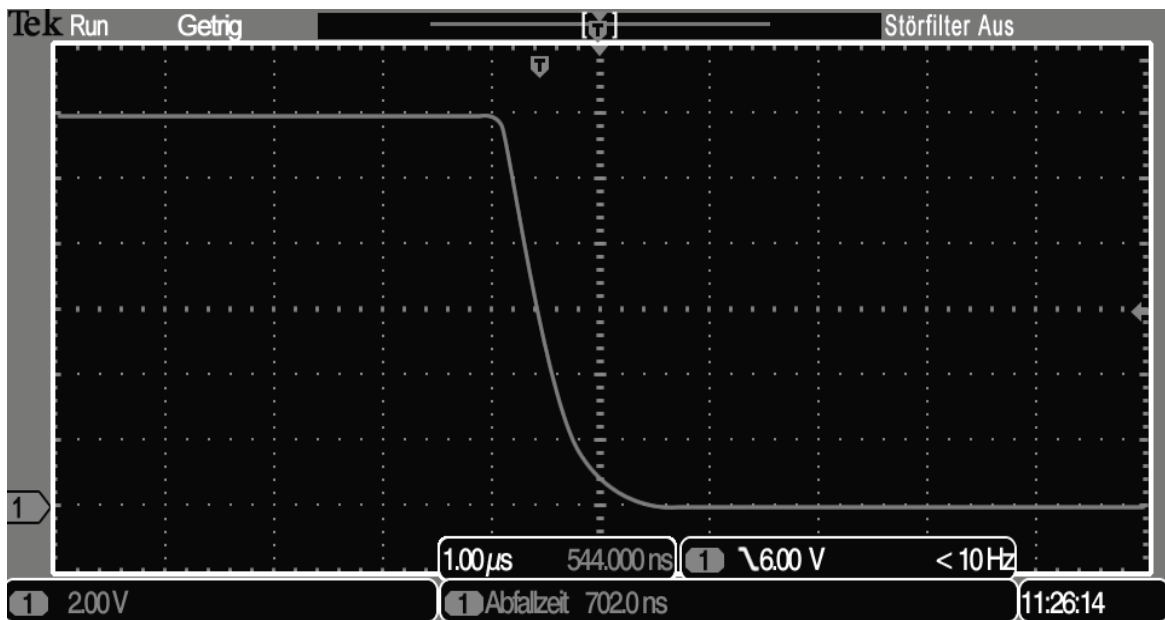

Two synchronous waveform signals

Analogue Amplifier / Signal Processing

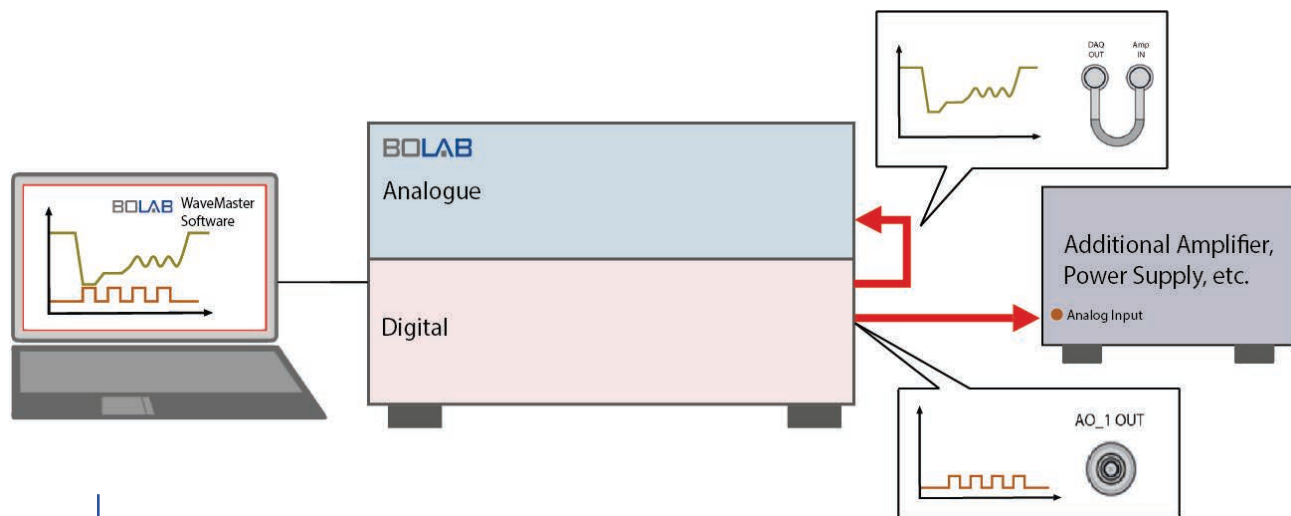

2 Analogue Outputs

- First output for control of the internal amplifier
- Second output for control of external hardware
- (amplifier / power supply)

4 Counter Inputs / Outputs

- Electronic switch S5
- Electronic switch S5 negated

16 Analogue Inputs

- Monitor U (internally wired) (New HMI)
- Monitor I (internally wired) (New HMI)
- Remaining inputs for measurements at user defined measuring points (New HMI)

24 Digital Inputs/ Outputs

- Run-Bit
- External Trigger
- Internal Trigger

Unlimited Waveform Memory

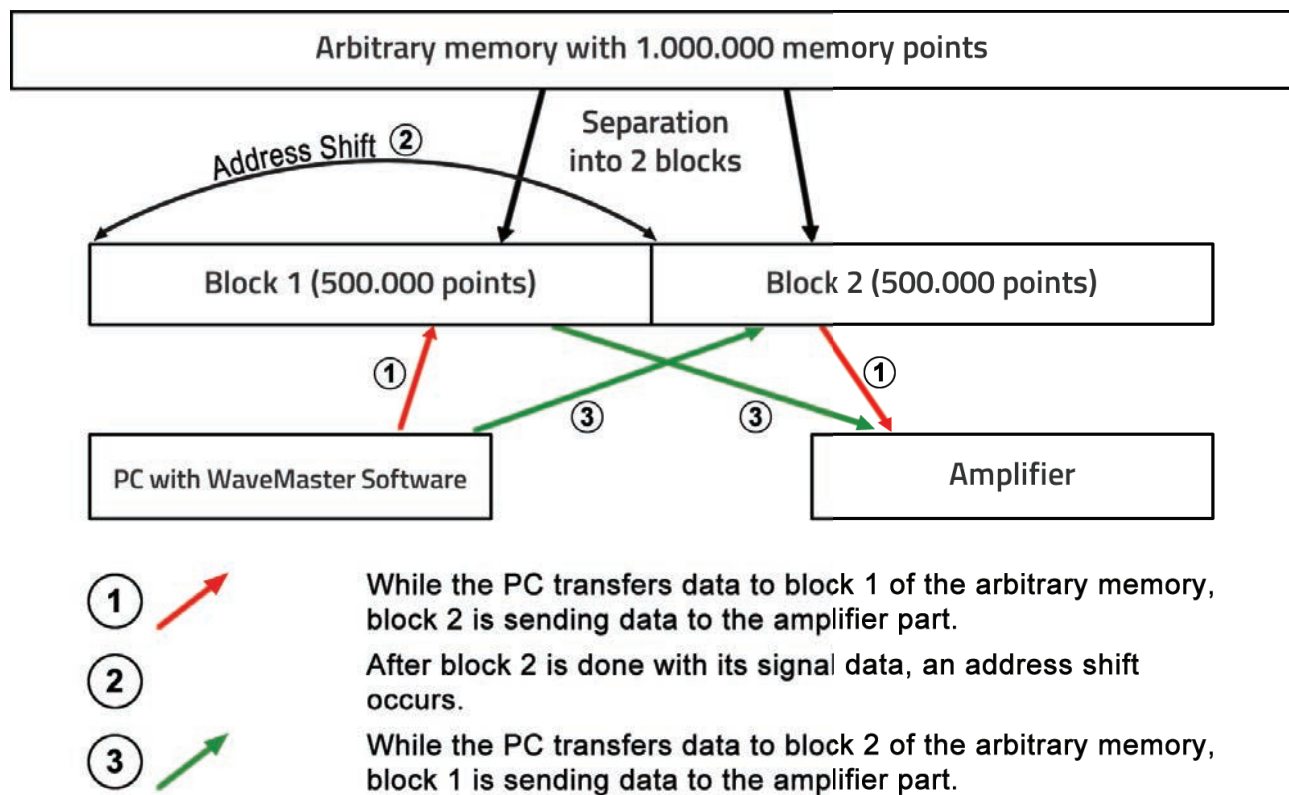

→ This technology enables an endless, continuous data stream to the amplifier.

- Compared to a function generator with its limited arbitrary memory there is no limitation of the size of the waveform.
- A waveform with small spikes and interruptions of e.g. 100 μ s and long constant levels in between can be simulated easily.



Analogue Remote Control

Multiple Control Possibilities

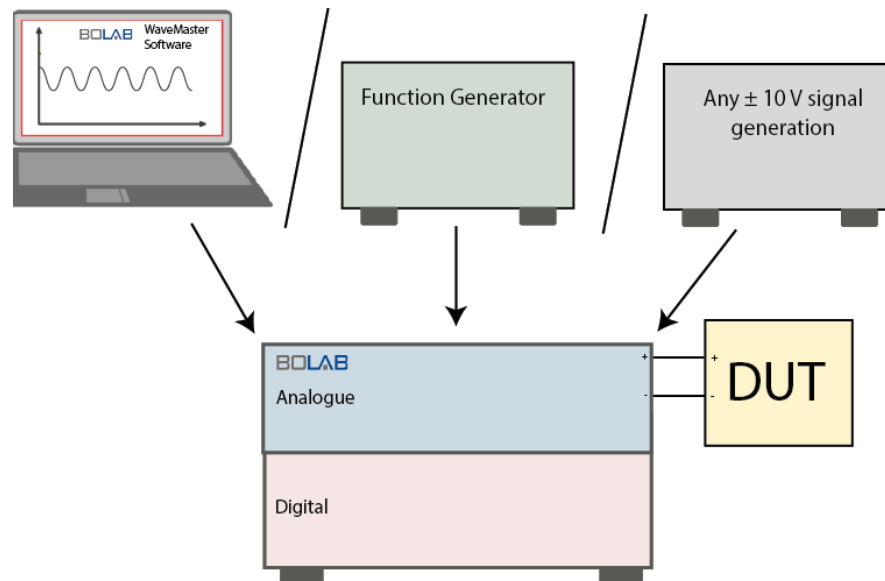

Amplifier Control

There are many ways to control BOLAB amplifier systems:

- **BOLAB WaveMaster Software:** This PC software generates waveforms, sends the curves to the internal data memory and runs the process. All selections in the instrument are done automatically.
- **Function Generator:** Standard function generators can be connected directly to the input of the amplifier.
- **NI DAQ Card, VT System (Vector), etc.:** Through their 0..±10 V input, other control units can be used for waveform generation. Automated test systems don't need programming adaptations.

Adding two independent signals to one waveform

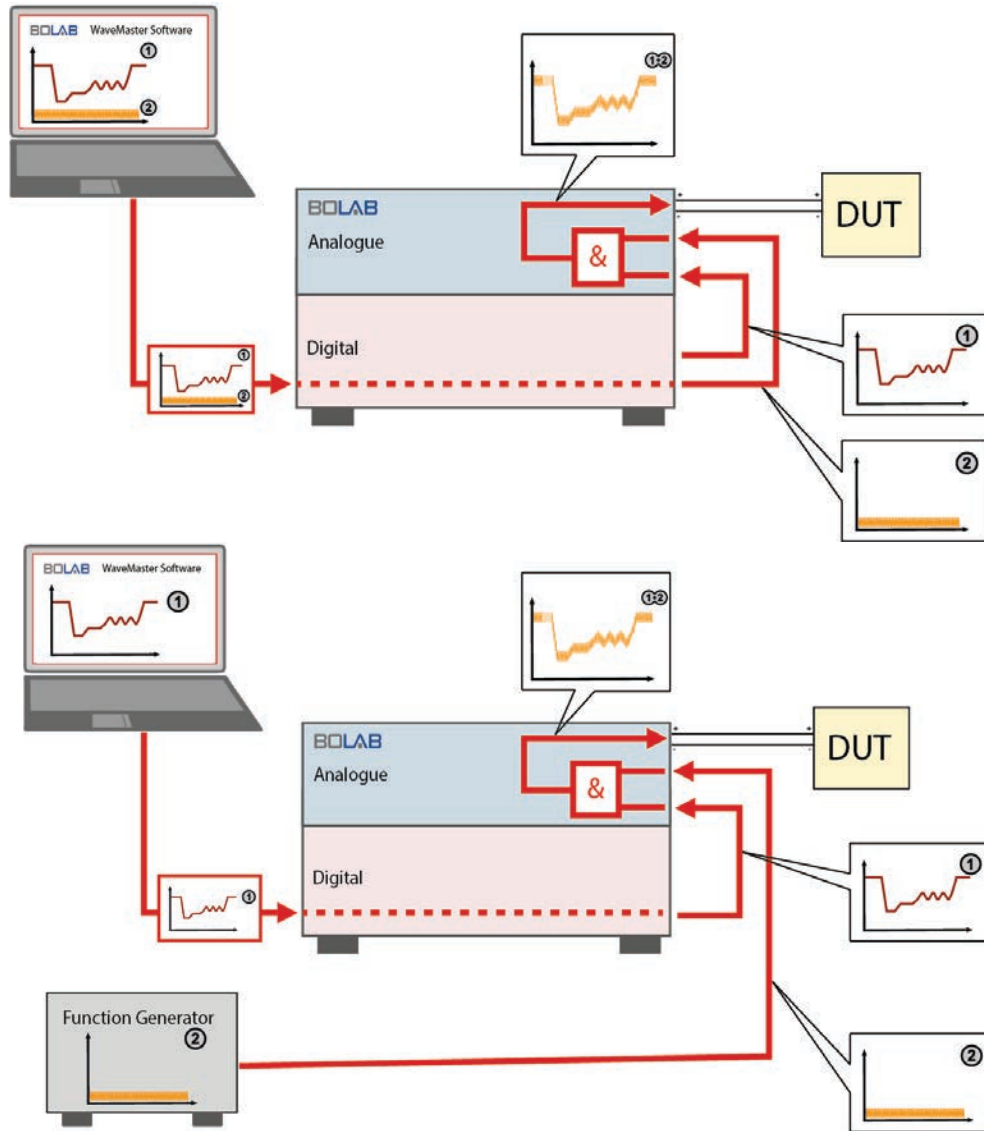

Amplifier Control

With an optional isolation amplifier, the instruments have two analog inputs. These inputs are added in the isolation amplifier. This allows to add e.g. an interference on a standard waveform. The second waveform may either come from the PC or from an external Function Generator.



Modular Design

Modular Concept / Modularly Expandable

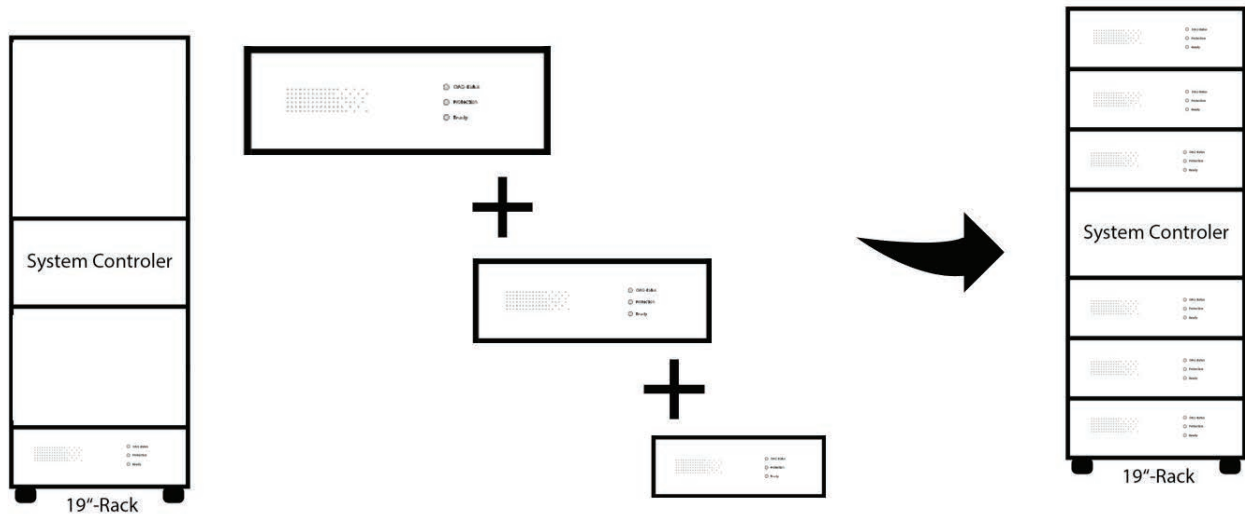

- Modular hardware architecture
- Starting with one single unit of e.g. 1 kW
- Extension up to 18 kW in parallel
- Building up 3-phase systems with up to 6 kW per phase
- Serial connection for increasing voltage
- In case of a defective module, only this modul needs to be repaired
- Each module has its own indication for functional capability

Voltage And Current Control

Both voltage and current control of the comprehensive amplifiers is possible. This can be selected on the front panel of the instrument.

Control input is $0 \dots \pm 10 \text{ V}$

for $0 \dots \pm V_{\text{rated}}$ respectively $0 \dots \pm I_{\text{rated}}$.

An optional compensation network for current control is necessary, which achieves highest slew rates and signal quality for current signals.



18 kW in parallel



WaveMaster Software

Waveform generation and 4-quadrant amplifier control

The powerful and easy to use WaveMaster software is unique in world market. Without any knowledge in software development, construction of ordinary and complex waveforms is dead easy.

A graphical waveform editor allows to generate individual curves in a flash. Also with a tabular input all kinds of waveforms can be produced immediately.

The simplicity how fast to import data out of oscilloscopes is amazing. Read in ASCII data files is possible in the same way.

Special Features

- Easy to use graphical waveform editor and tabular input possibility
- Command library for integration into automated test systems: LabView(TM), Vector CANoe (CAPL), C#, C++, ANSI C, Python, etc.
- Simulation of imported oscilloscope signals
- Waveform trigger caused by external TTL signal (rising edge) for synchronization
- Macro function for execution of automated tests

● Digital Interface USB

All functionalities of the 4-quadrant amplifiers are available in WaveMaster software for controlling the instruments. Short time current on/off, output on/off, operating voltage range and other functions can be easily set with its USB interface.

● Trigger Function

A hardware trigger input can be activate to monitor a TTL input signal on its rising edge. Synchronous waveform simulation, measurement and testing tasks are predestined applications.

● Macro Function

With a comfortable macro editor and its execution, selected waveforms run sequentially. Bursts, repetitions and loops make testing easy without any software coding.

● WaveMaster Remote DLL

With the WaveMaster remote DLL´s, available for nearly all programming languages, with its command library, users control the 4-quadrant amplifiers in an absolute perfection. There is no need to handle hardware interfaces such as USB or LAN.

One command for each function handles all interfaces. Data files are sent to the instrument within milliseconds. No need to concern about memory space and resolution of the amplifiers.

A simple "load" command calculates the best resolution of the waveform that is possible and sends data to the arbitrary unit. In every DLL (LabView™, Vector CANoe, C#, C++, ANSI C, Python, etc.), commands are identical. This makes switching between programming languages convenient. Commands for creating waveforms out of user programming surroundings are included as well. Variable waveforms for simulation of increasing ramps in time, variation of frequency and many other applications are typical test scenarios.



High Voltage

VW 80300 / LV 123: Electric vehicle test systems

Series operation solution allows to test HV components up to 1000 V DC. Standards like LV123, ISO 3637-4 and many others can be tested. With our 4-quadrant amplifier systems, interferences up to 200 kHz with an amplitude of more than 40 Vpp are possible.

Waveform libraries for

- LV 123
- VW 80300
- VW 30303
- PSA
- ISO 21498
- MBN LV 123
- Porsche
- etc.

Our Solution

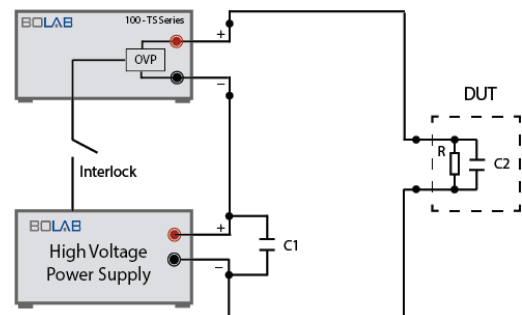

High Voltage Power Supply

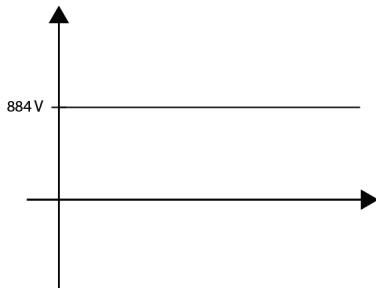

4-Quadrant Amplifier

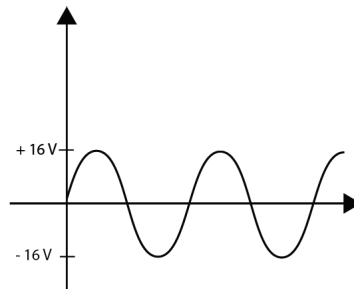

High Voltage Power Supply + 4-Quadrant Amplifier

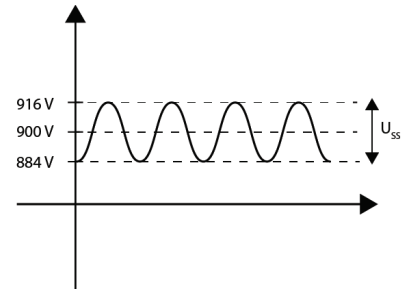

Artificial Network

AN-Series is an Artificial Network that electrically recreates the vehicular power-net impedance for component tests of voltage class B (high voltage) components in laboratories and test-benches. The AN-Series uses an analog system with a bandwidth covering up to 150 kHz. An artificial network like the AN-Series is crucial for the proper testing of all voltage class B component in both hybrid and electric vehicles. Generated DUT interferences like ripple, dynamics, spikes and other higher frequency noise is correctly absorbed and reflected by the Artificial Network, recreating conditions similar to that in a vehicular high voltage power-net. This allows for better testing of the component's robustness and its immunity to its own generated noise. Testing with AN-Series artificial network would also bring efficiency and life-cycle tests closer to real-world results and in line with standards like the ISO 21498, LV 123, IEC 61851-23, VW80300, MBN 11123 and internal-norm requirements.





Easy Programming

Python

● Special Features

- Ready to use for LabView™, Vector CANoe/ CAPL, C#, C++, ANSI C, Python, etc.
- Creating waveforms out of source code
- Predefined commands for sine waves, exponential functions, ramps, etc.
- Integration into HIL simulation systems
- Complete interface handling and configuration
- Starting and closing software out of application

● Example 1

This programming example in Python opens an existing data file, loads data into amplifiers memory, switches the output on and runs the application in a loop of five times.

```
import WaveMaster_PY27_x32
import time

#Create PYD object
wavemaster = WaveMaster_PY27_x32.CreateObject()
#Connect to the WaveMaster server
serverIPAddress = „10.99.92.78“
serverPortNumber = 700
arbnct.Connect(serverIPAddress,serverPortNumber)

#Open an existing file
fileName = „F:\\Waveform1MV.and“
openfileRet = wavemaster.OpenFile(fileName)

#Arbitrary System Function
sys=WaveMaster.GetArbitrarySystem()
#Configure the device settings
#Define source and amplifier
source = „NI DAQ USB-6259“
amplifier = „BOLAB 105-75N-TS“
#Set System
setSysRet = sys.Set(1,source,amplifier,0,0,0)
time.sleep(5)
#Load waveform into instruments memory
sys.Load()
#Enable output
sys.Execute()
#Start runnings of waveform with burst=5
sys.Start(5)
#Wait until waveform ends after 5 runnings
run = sys.IsRun()
while run == 1:
    time.sleep(0.5)
    run = sys.IsRun()
#Set output to standby
sys.Standby()

#Close file
openfileRet.Close()
#Disconnect from WaveMaster server
wavemaster.disconnect()
```

Example 2

Creating waveforms out of customers programming source code is quite easy:

```
using System;
using System.Collections.Generic;
using System.Linq;
using System.Text;
using WaveMaster_CPP_x32;

namespace TestCase2
{
    class Program
    {
        static void Main(string[] args)
        {
            //assuming WaveMaster is started externally in server mode
            RemoteWaveMasterDotNet _dllTest = new RemoteWaveMasterDotNet();
            Resource _sysResource = null;
            Resource _fileResNew = null;

            string ipAddress = „10.99.92.78“;
            int iport = 700;
            int res = -1;
            int layer = 1;
            string source = „NI DAQ USB-6259“;
            string amplifier = „BOLAB 105-75N-TS“;
            string online = string.Empty;
            string fileName = „F:\\Waveform2MV.and“;
            int fileType = 0x10;
            int run = 0;

            res = _dllTest.Connect(ipAddress, iport);
            Console.WriteLine(„1 - Connected to WaveMaster...“);
            res = _dllTest.NewFile(ref _fileResNew, fileType, fileName);
            if(res == 0)
                Console.WriteLine(„2 - New File created...“);
            res = _dllTest.AddDataFile(_fileResNew,1,0.0,0.0,5.0);
            if(res == 0)
                Console.WriteLine(„ - 1 New value in waveform added...“);
            res = _dllTest.AddDataFile(_fileResNew,1,0.1,12.0,5.0);
            if(res == 0)
                Console.WriteLine(„ - 2 New value in waveform added...“);
            res = _dllTest.AddDataFile(_fileResNew,1,0.5,12.0,5.0,1,50.0,10.0,2.0,0.0,0.0,0);
            if(res == 0)
                Console.WriteLine(„ - 3 Sine interference on waveform added...“);
            res = _dllTest.AddDataFile(_fileResNew,1,1.0,0.0,5.0);
            if(res == 0)
                Console.WriteLine(„ - 4 New value in waveform added...“);
            res = _dllTest.GetArbitrarySystem(out _sysResource);
            if (res == 0)
            {
                Console.WriteLine(„3 - GetArbitrarySystem...“);
                res = _dllTest.SetSystem(_sysResource,ref online,layer,source,amplifier,0,0,0);
                if (res == 0)
                {
                    res = _dllTest.LoadSystem(_sysResource);
                    if (res == 0)
                        Console.WriteLine(„5 - Write Waveform into instruments memory...“);
                    res = _dllTest.ExecuteSystem(_sysResource);
                    if (res == 0)
                        Console.WriteLine(„6 - Switch instruments output on...“);
                    res = _dllTest.StartSystem(_sysResource, 5);
                    if (res == 0)
                        Console.WriteLine(„7 - Run waveform 5 times...“);
                    res = _dllTest.IsRunSystem(_sysResource, out run);
                    if (res == 0)
                        Console.WriteLine(„8 - IsRunSystem...“);
                    while (run == 1)
                    {
                        System.Threading.Thread.Sleep(1000);//1 sec
                        res = _dllTest.IsRunSystem(_sysResource, out run);
                    }
                    res = _dllTest.StandbySystem(_sysResource);
                    if (res == 0)
                        Console.WriteLine(„9 - StandbySystem...“);
                }
            }
            res = _dllTest.SaveFile(_fileResNew, fileName);
            res = _dllTest.CloseFile(_fileResNew);
            res = _dllTest.Disconnect();
        }
    }
}
```



Technical Data

100-35R-TS - 30 V / + 35 V

Ranges / Current	105-35R-TS	110-35R-TS	120-35R-TS	130-35R-TS	140-35R-TS	150-35R-TS
Low voltage range -30 V...+16 V	20 A	40 A	76 A	114 A	152 A	190 A
Middle voltage range -30 V...+27 V	11 A	40 A	38 A	57 A	76 A	95 A
High voltage range -30 V...+35 V	11 A	30 A	27 A	40 A	53 A	67 A
Current peak 2 ms	50 A	100 A	190 A	285 A	380 A	475 A
Gain (voltage)	1 V / 10 V		1 V / 100 V			
Gain (current)	1 V / 10 A		1 V / 100 A			
DC-Offset	< 1 mV					
Monitor output (voltage)	1 V / 10 V		1 V / 100 V			
Monitor output (current)	1 V / 10 A		1 V / 100 A			
Residual Noise	< 7 mV					
Source power	500 W	1.000 W	2.000 W	3.000 W	4.000 W	5.000 W
Sink power	175 W	450 W	750 W	1.125 W	1.500 W	1.875 W
Slew rate	100 V / μ s		50 V / μ s			
CV-mode frequency bandwidth Small signal (-3 dB)	DC - 200 kHz DC - 1 MHz		DC - 200 kHz DC - 500 kHz			
CC-mode (option)	Depending on RC network					
Input impedance unbalanced	100 k Ω (1 k Ω)					
Instrument size	19", 3 HE	19", 4 HE	19", 39 HE			
Dimensions WxHxD (cm)	44,5 x 13,3 x 60,3	44,5 x 17,5 x 60,3	68 x 185 x 56			
Delivery	Instrument		19"-Rack			
Weight	20 kg	40 kg	150 kg	190 kg	230 kg	270 kg

Ranges / Current	105-35R-TS	110-35R-TS	120-35R-TS	130-35R-TS	140-35R-TS	150-35R-TS
Power Supply	230 V _{AC} (±10 %, 50 Hz ... 60 Hz)		3 x 230 V _{AC} (±10 %, 50 Hz ... 60 Hz)			
Protection	10 A		3 x 16 A			
Protective functions	Over Voltage Protection (OVP) Over Current Protection (OCP) Over Temperature Protection (OTP) P rotection against excessive power dissipation					
Operating temperature	10° C - 55° C					

Ranges / Current	160-35R-TS	180-35R-TS	200-35R-TS	220-35R-TS	250-35R-TS	280-35R-TS
Low voltage range -30 V...+16 V	228 A	304 A	380 A	456 A	570 A	684 A
Middle voltage range -30 V...+27 V	114 A	304 A	380 A	456 A	570 A	684 A
High voltage range -30 V...+35 V	80 A	228 A	285 A	342 A	429 A	516 A
Current peak 2 ms	570 A	760 A	950 A	1.140 A	1.425 A	1.710 A
Gain (voltage)	1 V / 100 V					
Gain (current)	1 V / 100 A					
DC-Offset	< 1 mV					
Monitor output (voltage)	1 V / 100 V					
Monitor output (current)	1 V / 100 A					
Residual Noise	< 7 mV					
Source power	6000 W	8.000 W	10.000 W	12.000 W	15.000 W	18.000 W
Sink power	2.225 W	3.500 W	4.400 W	5.300 W	6.6600 W	7.900 W



Ranges / Current	160-35R-TS	180-35R-TS	200-35R-TS	220-35R-TS	250-35R-TS	280-35R-TS
Slew rate	50 V / μ s					
CV-mode frequency bandwidth Small signal (-3 dB)	DC - 200 kHz DC - 500 kHz					
CC-mode (option)	Depending on RC network					
Input impedance unbalanced	100 k Ω (1 k Ω)					
Instrument size	19", 39 HE	2 x 19", 39 HE			3 x 19", 39 HE	
Dimensions WxHxD (cm)	Per 19"-Rack 68 x 185 x 56					
Delivery	19" Rack	2 x 19" Rack			3 x 19" Rack	
Weight	310 kg	2 x 230 kg	2 x 270 kg	2 x 310 kg	2 x 270 kg	2 x 310 kg
Power supply	3 x 230 V _{AC} (\pm 10 %, 50 Hz ... 60 Hz)					
Protection	3 x 16 A					
Protective functions	Over Voltage Protection (OVP) Over Current Protection (OCP) Over Temperature Protection (OTP) P rotection against excessive power dissipation					
Operating temperature	10° C - 55° C					

100-70R-TS -30 V / + 70 V

Ranges / Current	105-70R-TS	110-70R-TS	120-70R-TS	130-70R-TS	140-70R-TS	150-70R-TS
Low voltage range -30 V...+16 V	19 A	38 A	76 A	114 A	152 A	190 A
Middle voltage range -30 V...+27 V	19 A	38 A	76 A	114 A	152 A	190 A
High voltage range -30 V...+70 V	7 A	14 A	29 A	43 A	57 A	71 A

Ranges / Current	105-70R-TS	110-70R-TS	120-70R-TS	130-70R-TS	140-70R-TS	150-70R-TS
Current peak 2 ms	40 A	100 A	190 A	285 A	380 A	475 A
Gain (voltage)	1 V / 10 V		1 V / 100 V			
Gain (current)	1 V / 10 A		1 V / 100 A			
DC-Offset	< 1 mV					
Monitor output (voltage)	1 V / 10 V		1 V / 100 V			
Monitor output (current)	1 V / 10 A		1 V / 100 A			
Residual Noise	< 7 mV					
Source power	500 W	1.000 W	2.000 W	3.000 W	4.000 W	5.000 W
Sink power	240 W	470 W	940 W	1.400 W	1.800 W	2.400 W
Slew rate	100 V / μ s		50 V / μ s			
CV-mode frequency bandwidth Small signal (-3 dB)	DC - 200 kHz DC - 1 MHz		DC - 200 kHz DC - 500 kHz			
CC-mode (option)	Depending on RC network					
Input impedance unbalanced	100 k Ω (1 k Ω)					
Instrument size	19", 3 HE	19", 4 HE	19", 39 HE			
Dimensions WxHxD (cm)	44,5 x 13,3 x 60,3	44,5 x 17,5 x 60,3	68 x 185 x 56			
Delivery	Instrument		19"-Rack			
Weight	20 kg	40 kg	150 kg	190 kg	230 kg	270 kg
Power Supply	230 V _{AC} (\pm 10 %, 50 Hz ... 60 Hz)		3 x 230 V _{AC} (\pm 10 %, 50 Hz ... 60 Hz)			
Protection	10 A		3 x 16 A			
Protective functions	Over Voltage Protection (OVP) Over Current Protection (OCP) Over Temperature Protection (OTP) P rotection against excessive power dissipation					
Operating temperature	10° C - 55° C					



Ranges / Current	160-70R-TS	180-70R-TS	200-70R-TS	220-70R-TS	250-70R-TS	280-70R-TS
Low voltage range -30 V...+16 V	228 A	304 A	380 A	456 A	570 A	684 A
Middle voltage range -30 V...+27 V	228 A	304 A	380 A	456 A	570 A	684 A
High voltage range -30 V...+70 V	86 A	129 A	162 A	194 A	242 A	291 A
Current peak 2 ms	570 A	760 A	950 A	1.140 A	1.425 A	1.710 A
Gain (voltage)	1 V / 100 V					
Gain (current)	1 V / 100 A					
DC-Offset	< 1 mV					
Monitor output (voltage)	1 V / 100 V					
Monitor output (current)	1 V / 100 A					
Residual Noise	< 7 mV					
Source power	6.000 W	8.000 W	10.000 W	12.000 W	15.000 W	18.000 W
Sink power	2.800 W	3.800 W	4.700 W	5.600 W	7.000 W	8.400 W
Slew rate	50 V / μ s					
CV-mode frequency bandwidth Small signal (-3 dB)	DC - 200 kHz DC - 500 kHz					
CC-mode (option)	Depending on RC network					
Input impedance unbalanced	100 k Ω (1 k Ω)					
Instrument size	19", 39 HE	2 x 19", 39 HE			3 x 19", 39 HE	
Dimensions WxHxD (cm)	Per 19"-Rack 68 x 185 x 56					
Delivery	19"-Rack	2 x 19"-Rack			3 x 19"-Rack	
Weight	310 kg	2 x 230 kg	2 x 270 kg	2 x 310 kg	3 x 270 kg	3 x 310 kg
Power supply	3 x 230 V _{AC} (\pm 10 %, 50 Hz ... 60 Hz)					
Protection	3 x 16 A					

Ranges / Current	160-70N-TS	180-70N-TS	200-70N-TS	220-70N-TS	250-70N-TS	280-70N-TS
Protective functions	Over Voltage Protection (OVP) Over Current Protection (OCP) Over Temperature Protection (OTP) Protection against excessive power dissipation					
Operating temperature	10° C - 55° C					

100-75N-TS - 75 V / + 75 V

Ranges / Current	105-75N-TS	110-75N-TS	120-75N-TS	130-75N-TS	140-75N-TS	150-75N-TS
Low voltage range -25 V...+25 V	19 A	38 A	76 A	114 A	152 A	190 A
Middle voltage range -50 V...+50 V	10 A	19 A	38 A	57 A	76 A	95 A
High voltage range -75 V...+75 V	7 A	14 A	27 A	40 A	53 A	67 A
Current peak 2 ms	30 A	100 A	190 A	285 A	380 A	475 A
Gain (voltage)	1 V / 100 V					
Gain (current)	1 V / 100 A					
DC-Offset	< 1 mV					
Monitor output (voltage)	1 V / 100 V					
Monitor output (current)	1 V / 100 A					
Residual Noise	< 7 mV					
Source power	500 W	1.000 W	2.000 W	3.000 W	4.000 W	5.000 W
Sink power	150 W	375 W	750 W	1.125 W	1.500 W	1.875 W
Slew rate	100 V / μ s			50 V / μ s		
CV-mode frequency bandwidth Small signal (-3 dB)	DC - 200 kHz DC - 1 MHz			DC - 200 kHz DC - 500 kHz		
CC-mode (option)	Depending on RC network					



Ranges / Current	105-75N-TS	110-75N-TS	120-75N-TS	130-75N-TS	140-75N-TS	150-75N-TS
Input impedance unbalanced	100 k Ω (1 k Ω)					
Instrument size	19", 3 HE	19",4 HE	19", 39 HE			
Dimensions WxHxD (cm)	44,5 x 13,3 x 60,3	44,5 x 17,5 x 60,3	68 x 185 x 56			
Delivery	Instrument		19"-Rack			
Weight	20 kg	40 kg	150 kg	190 kg	230 kg	270 kg
Power Supply	230 V _{AC} (± 10 %, 50 Hz ... 60 Hz)		3 x 230 V _{AC} (± 10 %, 50 Hz ... 60 Hz)			
Protection	10 A		3 x 16 A			
Protective functions	Over Voltage Protection (OVP) Over Current Protection (OCP) Over Temperature Protection (OTP) P rotection against excessive power dissipation					
Operating temperature	10° C - 55° C					

Ranges / Current	160-75N-TS	180-75N-TS	200-75N-TS	220-75N-TS	250-75N-TS	280-75N-TS
Low voltage range -25 V...+25 V	228 A	304 A	380 A	456 A	570 A	684 A
Middle voltage range -50 V...+50 V	114 A	152 A	190 A	228 A	285 A	342 A
High voltage range -75 V...+75 V	80 A	106 A	133 A	160 A	200 A	240 A
Current peak 2 ms	570 A	760 A	950 A	1.140 A	1.425 A	1.710 A
Gain (voltage)	1 V / 100 V					
Gain (current)	1 V / 100 A					
DC-Offset	< 1 mV					
Monitor output (voltage)	1 V / 100 V					
Monitor output (current)	1 V / 100 A					
Residual Noise	< 7 mV					
Source power	6.000 W	8.000 W	10.000 W	12.000 W	15.000 W	18.000 W

Ranges / Current	160-75N-TS	180-75N-TS	200-75N-TS	220-75N-TS	250-75N-TS	280-75N-TS
Sink power	2.225 W	3.800 W	4.700 W	5.600 W	7.000 W	8.400 W
Slew rate	50 V / μ s					
CV-mode frequency bandwidth Small signal (-3 dB)	DC - 200 kHz DC - 500 kHz					
CC-mode (option)	Depending on RC network					
Input impedance unbalanced	100 k Ω (1 k Ω)					
Instrument size	19", 39 HE	2 x 19", 39 HE			3 x 19", 39 HE	
Dimensions WxHxD (cm)	Per 19"-Rack 68 x 185 x 56					
Delivery	19"-Rack		2 x 19"-Rack		3 x 19"-Rack	
Weight	310 kg	2 x 230 kg	2 x 270 kg	2 x 310 kg	3 x 270 kg	3 x 310 kg
Power supply	3 x 230 V _{AC} (\pm 10 %, 50 Hz ... 60 Hz)					
Protection	3 x 16 A					
Protective functions	Over Voltage Protection (OVP) Over Current Protection (OCP) Over Temperature Protection (OTP) Protection against excessive power dissipation					
Operating temperature	10° C - 55° C					



Test System Examples

130-70R-TS (3 kW)



160-70R-TS (6 kW)





Address

Muehlstetten 3
72351 Geislingen
Germany

Contact

Phone : +49 74 28 / 94 52 42 - 0
Fax : +49 74 28 / 94 52 42 - 20
Email : Info@BOLAB-Systems.de
Web : www.BOLAB-Systems.com